

CD540

DC Smart Power and Energy Meter



HIGH PERFORMANCE

- Economical
- Compact Design, Convenient Wiring
- Large LCD, White Backlight, Easy Reading
- 0.2% Accuracy on Voltage and Current

ENERGY

- Bi-Directional Energy
- IEC 62053-41: 0.5

DATA LOGGING

- Historical Log Available in 4 MB
- Record Metering Parameters with Time Stamp
- Parameter Sources: Voltage, Current, Power, Energy, Ampere-Hour

STATISTIC/ALARM

- Max/Min Values with Time Stamp
- Over/Under Limit Alarm

APPLICATIONS

- DC Energy Management System
- Power Distribution System
- Renewable Energy
- Wind Turbine Power Generation
- Industrial DC Control System
- Metallurgy & Electroplating Industries
- Solar PV
- Electric Vehicle Charging



FEATURES

Metering

- Voltage
- Current
- Power
- Ampere-Hour

Max/Min Record

- Max/Min Parameter
- Parameter Sources: Voltage, Current, Power

I/O Functions

- Digital Input: Monitor Switch Status
- Relay Output: Relay Command Control Output ON/OFF; Limit Alarm Control Output

Communication

- Modbus RTU via RS485 Port
- Support Connect to SCADA, PLC or Other External Systems

Display

- LCD Display, White Backlight
- View Metering Parameters

DIMENSIONS

Unit: mm

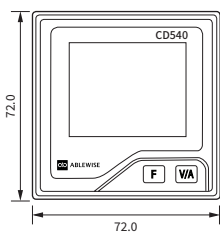

Front View

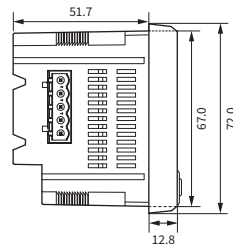

Side View

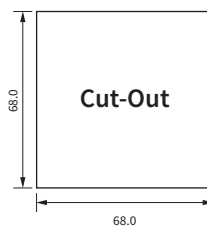

Cut Out

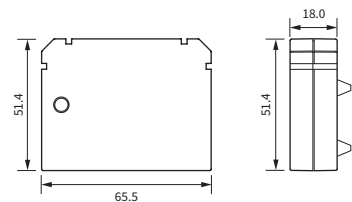

I/O Module Dimensions

TYPICAL WIRING

Current Wiring using Shunt

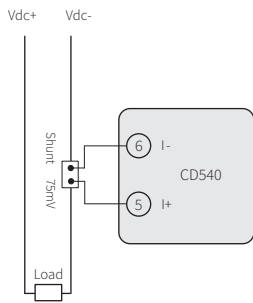

Voltage Wiring using Voltage Hall Effect Sensor

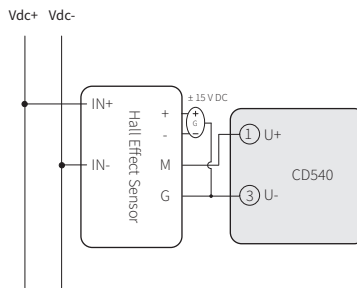

Voltage & Current Wiring using Shunt

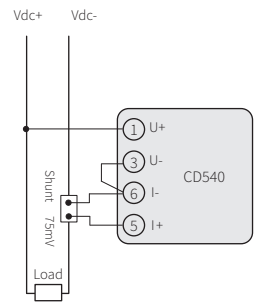

Voltage & Current Wiring using Current Hall Effect Sensor

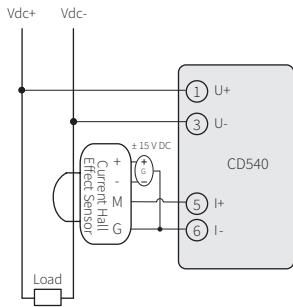

Voltage & Current Wiring using Voltage Hall Effect Sensor

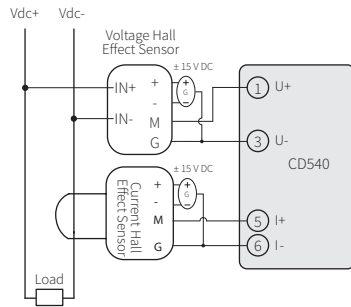

Digital Input

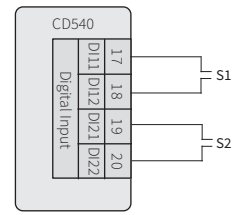

Relay Output (<250 V AC or 30 V DC, I<3 A)

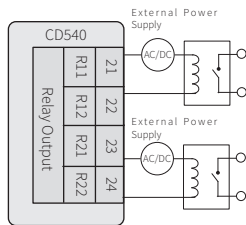

Power Supply Wiring

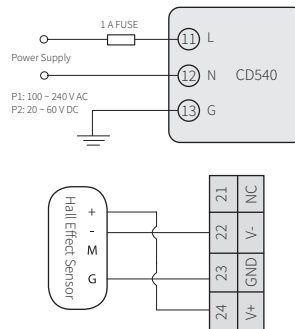

TERMINAL DIAGRAM

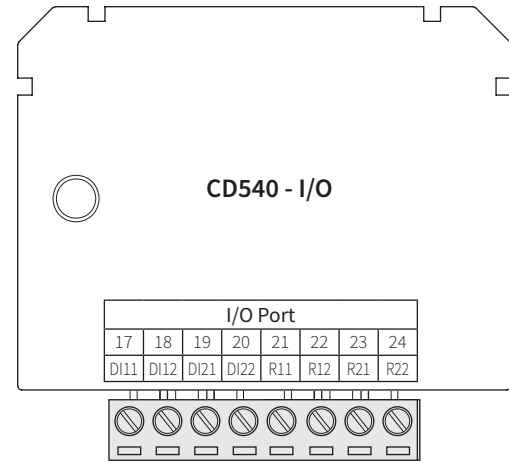
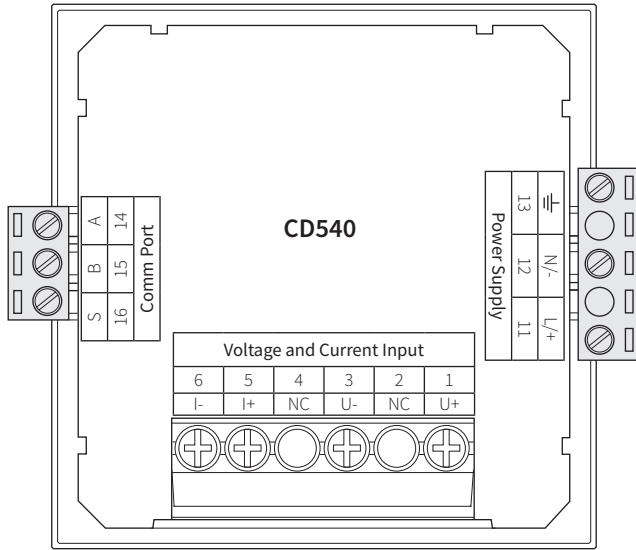

SPECIFICATION

Parameters	Accuracy	Resolution	Range
Voltage	0.2%	0.001 V	0 ~ 9999 V
Current	0.2%	0.001 A	0 ~ ±50000 A
Power	0.5%	0.001 kW	0 ~ ±60000 kW
Energy	0.5%	0.01 kWh	0 ~ 9999999.99 kWh
	0.5%	0.001 kWh	0 ~ 999999.999 kWh
	0.5%	0.0001 kWh	0 ~ 9999999.9999 kWh
Ampere-Hour	0.5%	0.01 Ah	0 ~ 999999.99 Ah
DI Count			0 ~ 4294967295
Temperature Drift	<100 ppm/°C		
Stability	0.5%/year		

Voltage	
Voltage	Direct Input: 0 ~ 1000 V Via Hall Effect Sensor: 0 ~ 9999 V
Input Impedance	2 MΩ
Load	<0.6 W
Accuracy	0.2%
Current	
Shunt	0 ~ ±50000 A (Via Shunt or Hall Effect Sensor, Programmable Range) Output: 50 ~ 100 mV (Programmable)
Hall Effect Sensor	Output: 0 ~ ±5 V/0 ~ ±4 V
Power Consumption	3 W (Max)
Accuracy	0.2%
Digital Input	
Input Type	Dry
Isolation Voltage	2500 V AC

Relay Output (RO)	
Type	Mechanical Contact, Form A
Switching Voltage	250 V AC/30 V DC
Switching Current	3 A
Contact Resistance	100 mΩ (Max)
Isolation Voltage	4000 V AC
Mechanical Life	5×10 ⁶
±15 V DC Power Supply	
Output Voltage Range	±15 V DC
Error	< ±10%
Output Current	±66.6 mA (Max)
Isolation Voltage	3000 V DC

Communication	
Type	RS485
Communication Protocol	Modbus RTU
Baud Rate	1200 ~ 38400 bps
Isolation Voltage	2500 V AC

Power Supply	
Operating Range	(P1)100 ~ 240 V AC, 50/60 Hz, 100 ~ 300 V DC (P2)20 ~ 60 V DC
Power Consumption	3 W (Typical)

Operating Environment	
Operating Temperature	-25 ~ 70 °C
Storage Temperature	-40 ~ 85 °C
Relative Humidity	5% ~ 95% (Non-Condensing)

CD540 DIN-RAIL MOUNT (CD-DIN)



DIMENSIONS *CD540 Dimensions*

Unit: mm

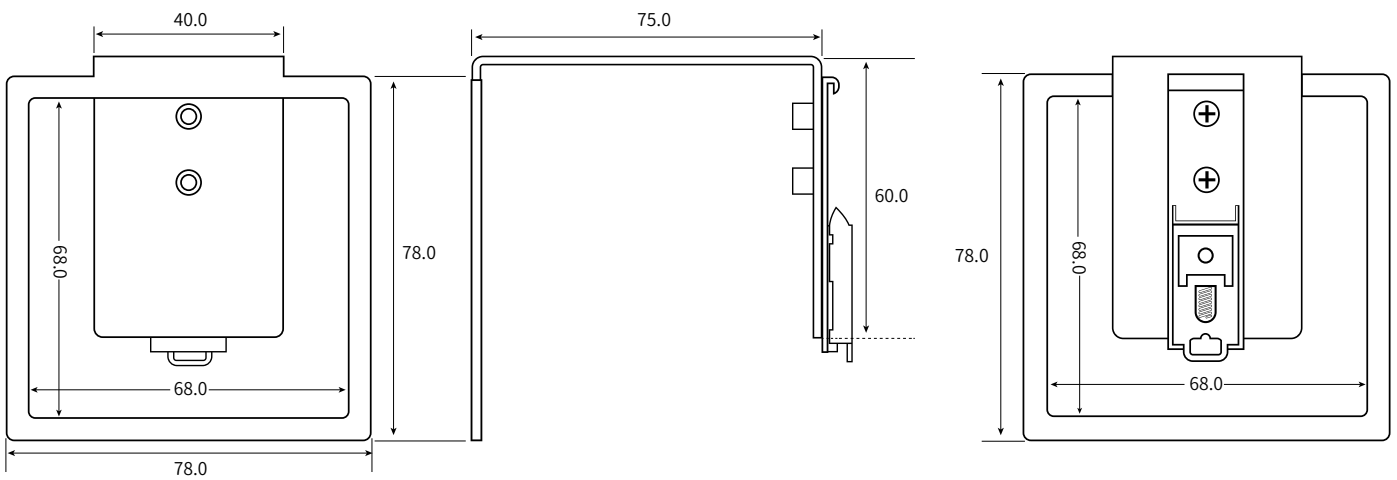

ORDERING INFORMATION

Model	Voltage Input	Current Input	Power Supply	I/O Option
CD540	- 1000V: Nominal Input Voltage 1000 V DC	- A1: Shunt (50 ~ 75 mV)	- P1: 100 ~ 240 V AC , 50/60 Hz, 100 ~ 300 V DC	- X3: 2 DI + 2 RO
	- 60V: Nominal Input Voltage 60 V DC	- A3: Voltage Hall Effect Sensor (0 ~ ±5 V/0 ~ ±4 V)	- P2: 20~60 V DC	X5: 2 DI + ±15 V DC
	5V: Via Hall Effect Sensor (0 ~ 5 V/0 ~ 4 V), Ratio Settable			

Ordering Example: CD540-1000V-A3-P1-X5

Accessories (Optional)	
Ordering Information	- CD-DIN

Revision Date: Apr., 2024 V1.02

