

AVM200

Multi-Function Power and Energy Meter



COST-EFFECTIVE

- High Performance, Low Cost
- IP Degree of Protection: IP66/NEMA 4, Front Side
- Large LCD, White Backlight, Easy Reading

RTD SUPPORTED

- Resistance Temperature Detectors for Electrical Contacts
- Suitable for Cables or Terminals
- Range: 0.0°C ~ 125.0°C

STATISTICS / ALARM

- Max/Min Values with Time Stamp
- Peak Demand with Time Stamp
- Over/Under Limit Alarm

REVENUE METERING

- IEC 62053-22 0.5S and ANSI C12.20 0.5
- TOU, Four Tariffs, 12 Seasons, 14 Schedules
- Four Quadrant Power and Energy



APPLICATIONS

- Energy Management System
- Industrial Facility Metering
- Commercial Metering
- Building Automation and Control Systems
- Intelligent Building
- Medium and Low Voltage Systems
- Energy Management and Power Quality Monitoring

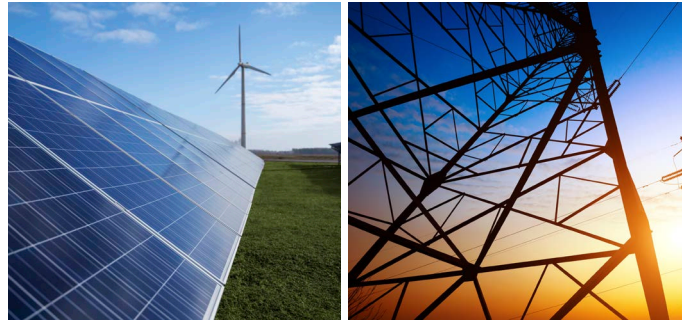

FEATURES

Metering

- Phase-to-Neutral Voltage, Line-to-Line Voltage, Current
- Active Power, Reactive Power, Apparent Power, Power Factor
- Frequency

Power Quality

- Voltage Unbalance, Current Unbalance
- THD, TOHD, TEHD and Individual Harmonics to 31st
- Crest Factor, THFF, K Factor
- Voltage and Current Phase Angles

Energy and Energy Record

- Bi-Directional and Four Quadrant Total Energy
- Single-Phase Energy
- Daily and Monthly Energy Record

Time of Use (TOU)

- Two TOU Settings can Automatically Switch at the Setting Time
- Four Tariffs, 12 Seasons, 14 Schedules

Alarms

- Over or Under Setting Limit
- Up to 50 Power Measurement Parameters can be Set
- Alarm can Trigger the Relay Output, Screen Flashing

Max/Min Record

- Max/Min Parameter Value and Time Stamp
- Parameter Sources: Voltage, Current, Power, Frequency, etc
- Peak Demand Record

Multiple I/O Functions

- Digital Output: Energy Pulse Output
- Digital Input: Monitor Switch Status or Pulse Count; SOE Record
- Relay Output: Relay Command Control Output ON/OFF; Limit Alarm Control Output
- Analog Output

Resistance Temperature Detectors (RTD)

- Suitable for Cables or Terminals
- Range: 0.0°C~125.0°C

Display

- Large LCD, White Backlight
- View Metering Parameters, Energy, Power Quality and Setting Value

DIMENSIONS

Unit: mm

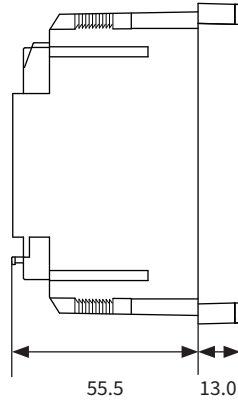
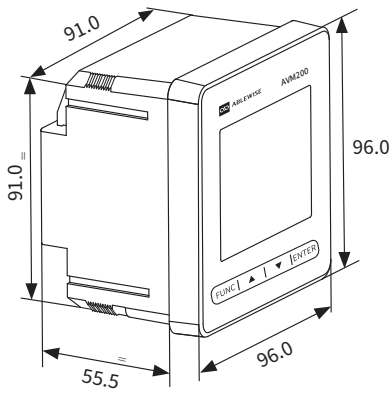

Side View

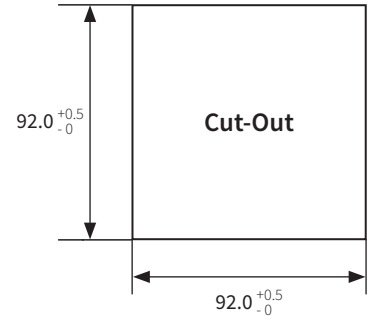

Cut Out

TERMINAL DIAGRAM

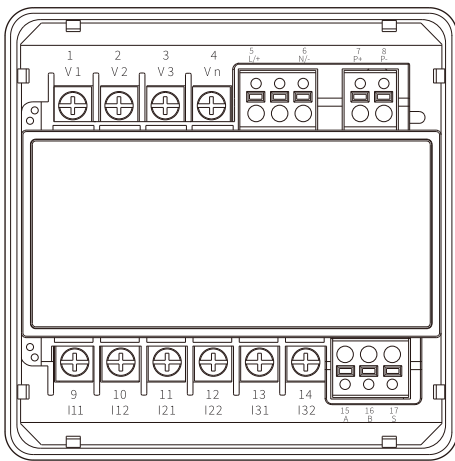

AVM200

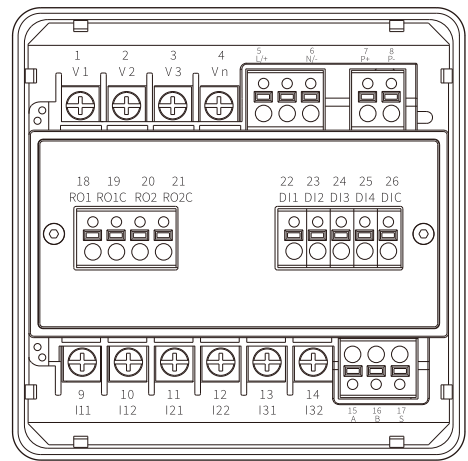

AVM200-DIO

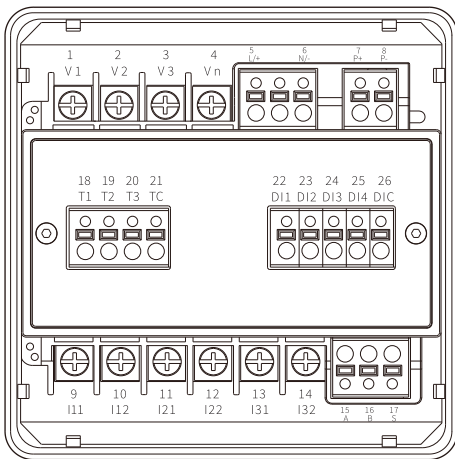

AVM200-DIT

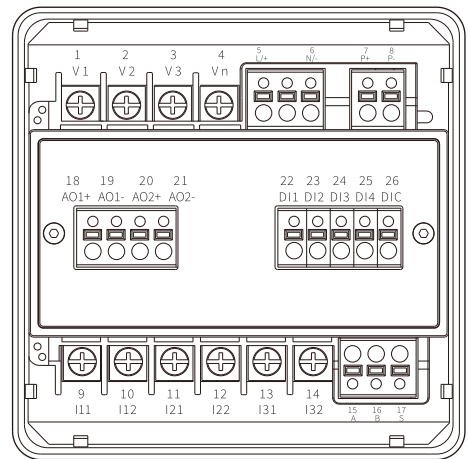

AVM200-DIA

TYPICAL WIRING

3LN, 3CT

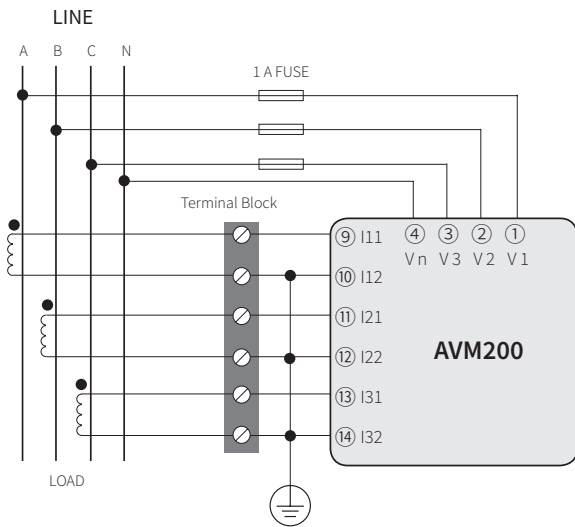

2LN, 2CT

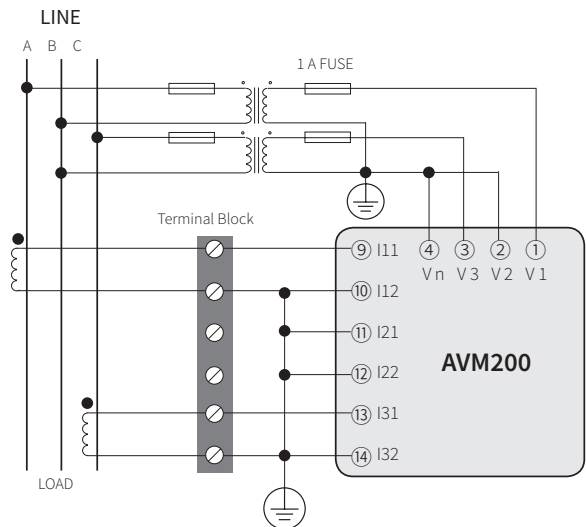

Relay Output

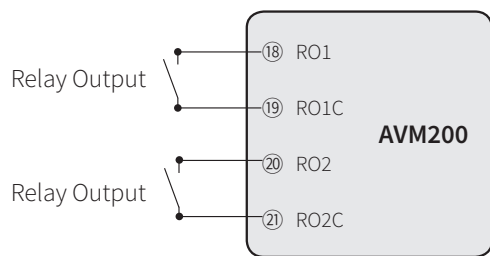

Temperature Measurement

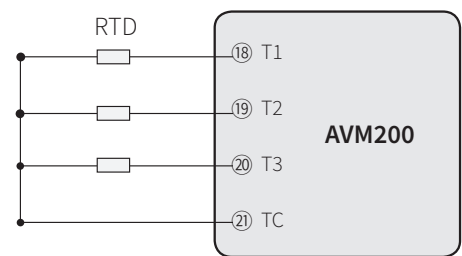

Analog Output

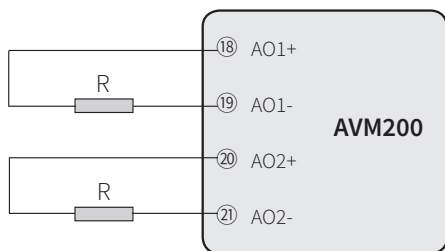

Digital Input

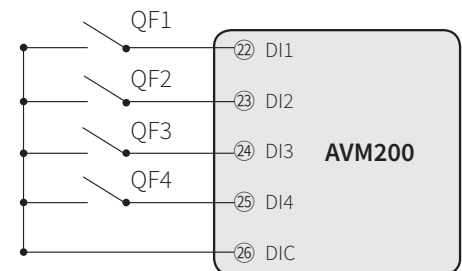

SPECIFICATION

Parameters	Accuracy	Resolution	Range
Voltage	0.2%	0.1 V	10 V ~ 1000 kV
Current	0.2%	0.001 A	5 mA ~ 50000 A
Active Power	0.5%	1 W	-9999 ~ 9999 MW
Reactive Power	0.5%	1 var	-9999 ~ 9999 Mvar
Apparent Power	0.5%	1 VA	0 ~ 9999 MVA
Power Factor	0.5%	0.001	-1.000 ~ 1.000
Frequency	±0.02 Hz	0.01 Hz	45 ~ 65 Hz
Active Energy	0.5S	0.1 kWh	0 ~ 99999999.9 kWh
Reactive Energy	1.0S	0.1 kvarh	0 ~ 99999999.9 kvarh
Apparent Energy	0.5%	0.1 kVAh	0 ~ 99999999.9 kVAh
Harmonics	1.0%	0.01%	
Unbalance	2.0%	0.1%	0.0% ~ 100.0%
Phase Angle	1.0%	0.1°	0.0° ~ 359.9°
Running Time	-	0.01 h	0 ~ 9999999.99 h
Temperature	±2°C	0.1°C	0.0°C ~ 125.0°C

Voltage Input	
Nominal Voltage	230 V AC L-N, 400 V AC L-L, CATIII 400 V AC L-N, 690 V AC L-L, CATII
Accuracy	0.2%
Input Impedance	2 MΩ/Phase
Withstand	740 V Continuous (Max)

Current Input	
Nominal Current	5 A/1 A
Accuracy	0.2%
Starting Current	5 mA
Burden	<0.05 VA (Typical) @5 A
Withstand	2X In Continuous, 100 A rms for 1 second, Non-Recurring

Energy Pulse	
Input Voltage	5 ~ 30 V DC
Current	5 ~ 50 mA
Pulse Source	Active & Reactive Energy

Digital Input (DI)	
Input Type	Dry
Input Impedance	10 kΩ (Typical)
Input Voltage Range	10 ~ 30 V DC
SOE Resolution	1 ms
Isolation Voltage	3500 V AC

Relay Output (RO)	
Switching Voltage (Max)	250 V AC or 30 V DC
Switching Current (Max)	5 A (R) 2 A (L)
Set Time	10 ms (Max)
Contact Resistance	100 mΩ (Max)
Isolation Voltage	3500 V AC
Mechanical Life	2 × 10 ⁷

Analog Output (AO)	
Output Range	0 ~ 20 mA/4 ~ 20 mA
Accuracy	0.5%
Temperature Drift	50 ppm/°C Typical
Isolation Voltage	3500 V AC
Open Circuit Voltage	15 V

Operating Environment	
Operating Temperature	-25 ~ 70 °C
Storage Temperature	-40 ~ 85 °C
Relative Humidity	5% ~ 95% (Non-Condensing)
IP Degree of Protection	IEC 60529, IP66 (Front Panel), IP30 (Housing)

Power Supply	
Operating Range	100 ~ 240 V AC, 50/60 Hz; 100 V ~ 300 V DC
Power Consumption	3 W, 6 VA, Max

Standards Compliance	
Product Standard	
Product Standard	IEC 61557-12
Energy Accuracy	
Active Energy	IEC 62053-22 Class 0.5S ANSI C12.20 0.5
Reactive Energy	IEC 62053-24 Class 1.0S
Safety Standard	
Safety Standard	IEC 61010-1 ed.3; IEC 61010-2-30 ed.2; CATIII
Electromagnetic Compatibility	
Electrostatic Discharge Immunity	IEC 61000-4-2
Radiated Field Immunity	IEC 61000-4-3
Fast Transients Immunity	IEC 61000-4-4
Surge Immunity	IEC 61000-4-5
Conducted Disturbances Immunity	IEC 61000-4-6
Power Frequency Magnetic Field Immunity	IEC 61000-4-8
Radio-Frequency and Radio Disturbance	CISPR 11/CISPR 22 EN 55011/EN 55022

ORDERING INFORMATION

Model	Options	RTDs Mode
AVM200	-	Blank: No Option
	-	DIO: 4 Digital Inputs, 2 Relay Outputs
	-	DIT: 4 Digital Inputs, 3 RTDs
	-	DIA: 4 Digital Inputs, 2 Analog Outputs

M0: Cable Mode
M8: φ 8 Switch Contact
M10: φ 10 Switch Contact
M12: φ 12 Switch Contact

Ordering Example: AVM200-DIT-M0

RESISTANCE TEMPERATURE DETECTORS (RTD)

Switch Contact Dimensions (M8/M10/M12)

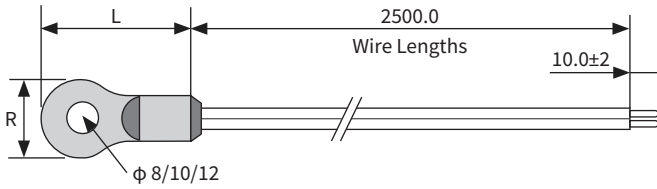

Note: Customized wire lengths are available.

Hole Diameter Φ(mm)	External Diameter R(mm)	Lengths L(mm)	Circuit Breaker Rated Current
8	15	28	100 A/125 A/160 A/250 A
10	20	33.8	400 A
12	24	38.8	630 A/800 A

Cable Mode Dimensions (M0)

Unit: mm

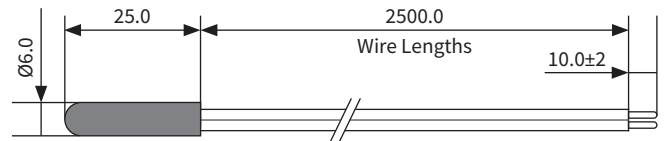

Switch Contact

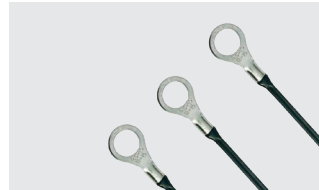

Cable Mode



Revision Date: Apr., 2024 V1.02

